

・パナソニックグループ化学物質管理ランク指針最新版(製品版)を遵守すること。
 URL:http://panasonic.co.jp/procurement/green/
 ・Observe the Panasonic Group Chemical Substances Management Rank Guidelines latest version (For Products).
 URL:http://panasonic.net/procurement/green/

SYM.	DATE	REVISION	SIGNED	CHECKED
△				
△				
△				

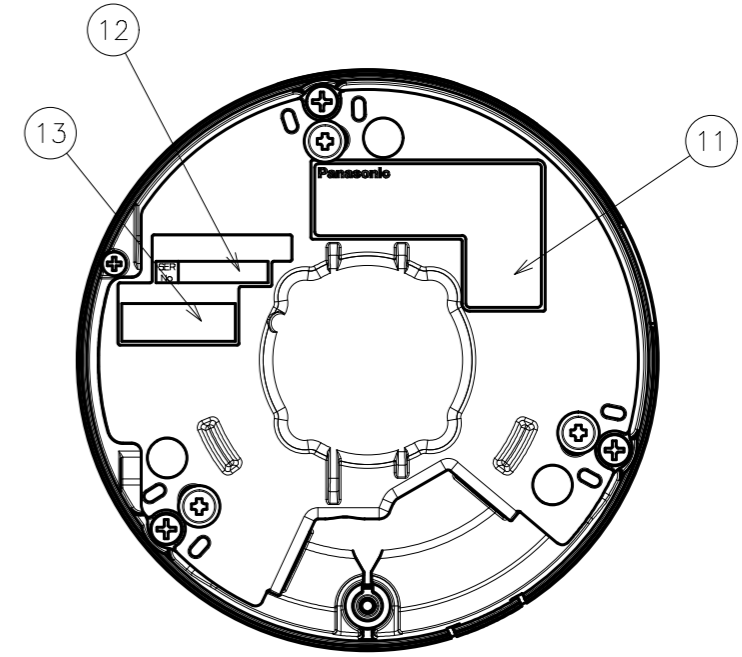

Without Attachment Plate

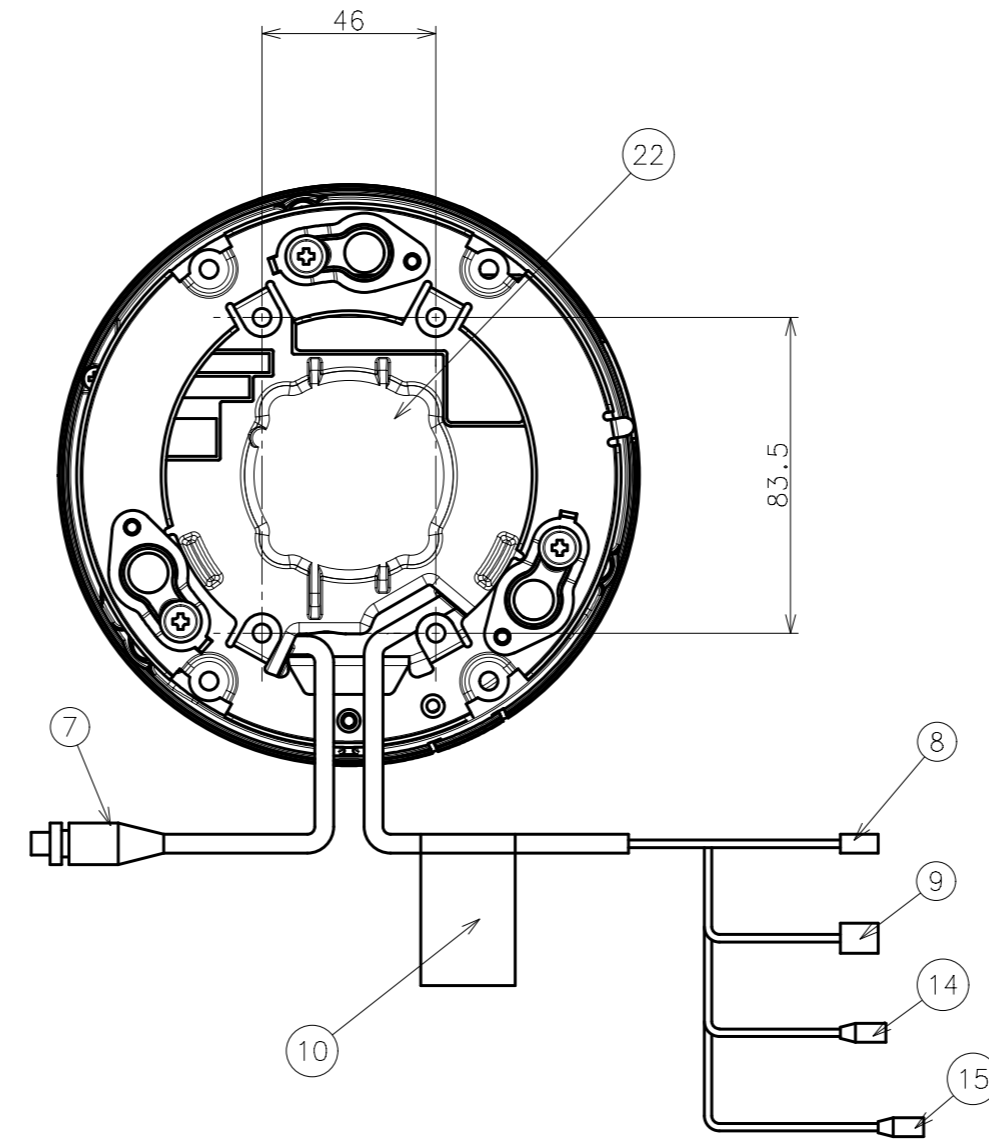
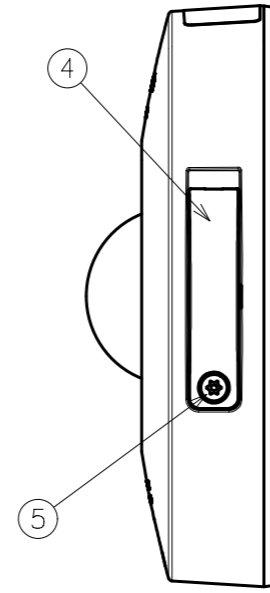
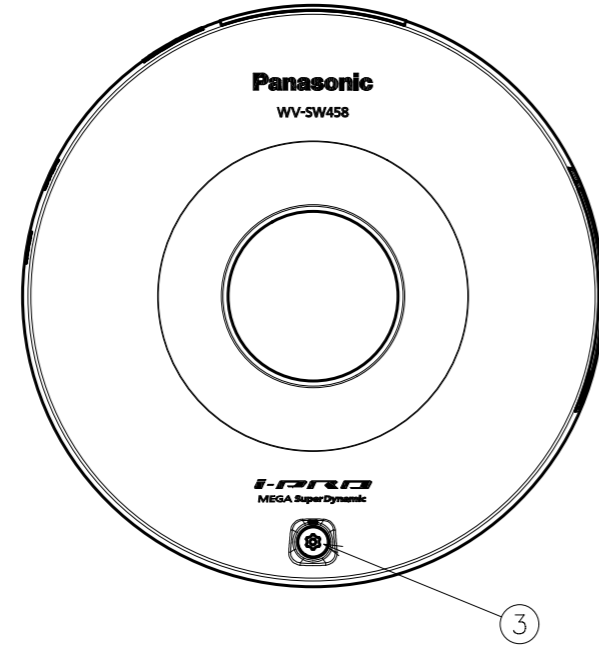
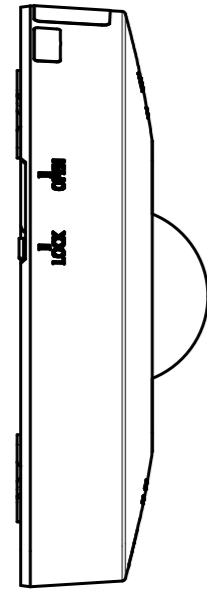
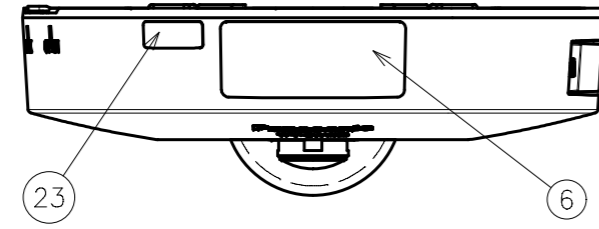
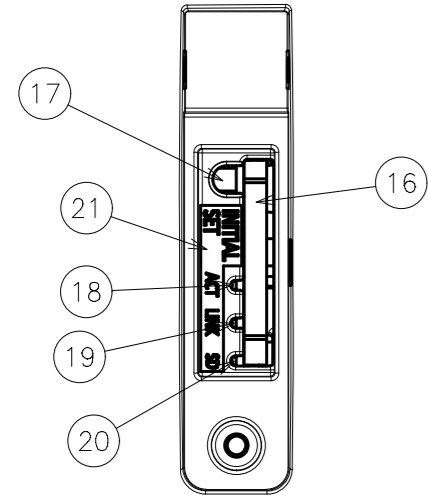

Inside of SD-slot cover (S=1/1)

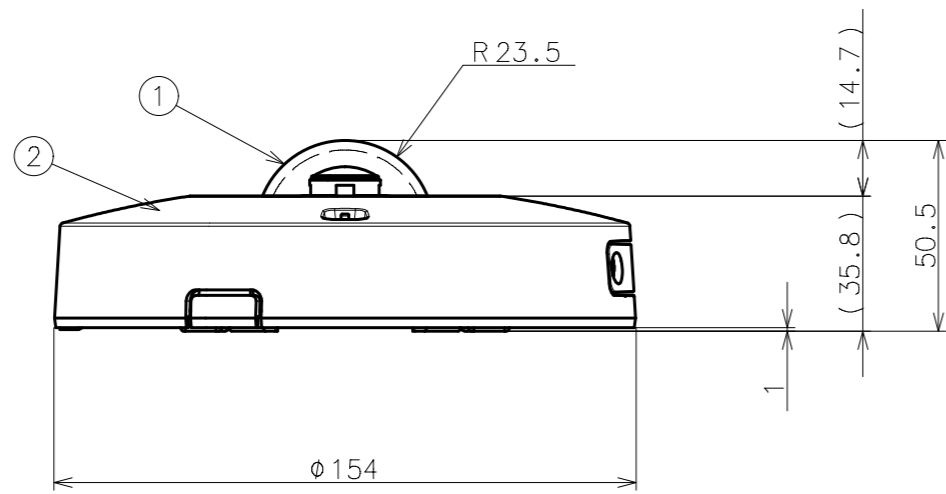

No.	Part Name	QTY	MATERIAL & SIZE	TREATMENT	REMARK
23	Type 4X Label	1	Polyester Film	-	-
22	Lower Case	1	Aluminium Alloy Diecasting	Painted(Black)	-
21	SD-slot Label	1	Polyester Film	-	-
20	SD memory card error indicator LED	1	-	-	-
19	Link indicator LED	1	-	-	-
18	Access indicator LED	1	-	-	-
17	INITIAL SET button	1	-	-	-
16	SD memory card slot	1	-	-	-
15	MIC Cable	1	-	-	-
14	Audio Output Cable	1	-	-	-
13	Code Label	1	-	Printing	-
12	SERIAL NUMBER Label	1	Polyester Film	Printing	-
11	Name Label	1	Polyester Film	Printing	-
10	Wiring Attention Label	1	Polyester Film	Printing	-
9	Alarm I/O Cable	1	-	-	-
8	Power Cable	1	-	-	-
7	Network Cable (M12 connector)	1	-	-	-
6	FCC/DOC Label	1	Polyester Film	Printing	-
5	SD CARD Cover Lock Screw	1	Stainless Steel	-	-
4	SD CARD Cover	1	Aluminium Alloy Diecasting	Painted (Light Gray)	-
3	Camera Lock Screw	1	Stainless Steel	-	-
2	Upper Case	1	Aluminium Alloy Diecasting	Painted (Light Gray) & Printing	-
1	Dome Cover	1	PC	-	-

REMARK	Weight Camera:Approx. 670g Attachment:Approx. 90g	MATERIAL & SIZE	PROCESS	MODEL	WV-SW458MP
SCALE	DESIGNED	DRAWN	CHECKED	APPROVED	NAME
1:2	T.Uchida 12.08.07	H.Shiraishi 12.08.08		I.Konimura 12.08.08	APPEARANCE
				DRAWING/ Part NO.	M-Mb1 of M-Mb1
				REF.NO.	/

記号	図番又は部品品番	図名又は部品名	数量	材質・寸法	処理・加工	記事